



Manufacturer of Butweld Pipe Fittings
Forged Fittings, Flanges & Fasteners
|| Since 1972 ||



INSTRUMENTATION

PIPE FITTINGS

PIPING SOLUTIONS

ADDITIONAL PRODUCTS

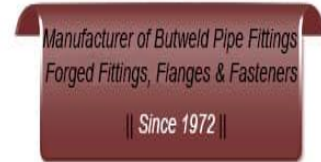

BUTTWELD FITTINGS TO ANSI B16.9 AND 16.28

Dimensions

Dimensions of Elbows, Tees, Caps and Reducers from ½" NB to 60" short Radius Elbows and Return Bends from Bends from 1" to 24" N.B. and Long Radius Bends from ½" N.B. to 24 are as stated in the current editions of ANSI B 16.9 and B-16.28 wall thickness are as listed ANSI B 36.10M.

Material

Stainless Steel : ASTM A403, WP 304 / 304L / 304H / 316 / 316L / 317 / 317L / 321 / 310 / 347 / 904L etc.

Carbon Steel : ASTM A234 WPB / A420 WPL3 / A420 / WPL6 / MSS-SP-75 WPHY 42 / 46 / 52 / 56 / 60 / 65 / 70

Alloy Steel : ASTM A234 WP1 / WP5 / WP9 / WP11 / WP22 / WP91 etc.

Manufacture & Heat Treatment

In accordance with the relevant ASTM or MSS Specification.

Weld Preparation

All fittings have a weld preparation to ANSI B 16.25

Marking

Fittings are marked with : the nominal size (or sizes) ; schedule or wall thickness; material grade; that reference manufacturer's mark. Where the size of fittings does not permit full marking then nominal size(s); schedule or wall thickness; and material grade are omitted.

Test Certificate

Fittings test certificates are available and are supplied with all goods. Test Certificates include full chemical analysis and Mechanical Properties with 3.1 Certificate, Impact Test & NACE MR 0175 / MR 0103 in addition as per requirement.

Inspection

All stock is statically sample inspected on receipt. The sampling plan is selected from BS6001.

OTHER PRODUCTS AVAILABLE

Other Schedules / wall thicknesses Nickel base alloys, Copper, Nickel & Duplex are available from short delivery time.

DIMENSION OF BUTT WELDING FITTINGS TO ANSI B 16.6/MSS SP 43

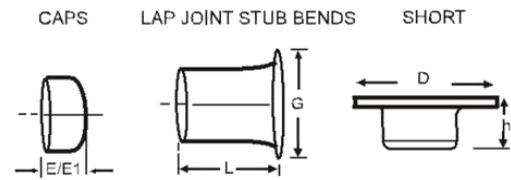
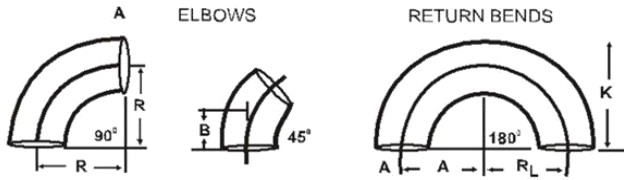

NOM BORE	PIPE OD	RADIUS 'R'					E/E1	LENGTH 'L'			
		1 D	1.5 D	B 1.5 D	K	G		MSS SP 43	ANSI B 16.9	D	H
		1/2	21.3	12.7	38.1	15.9		48	25.4	34.9	50.8
3/4	26.7	19.05	38.1	19.0	51	25.4	42.8	50.8	76.2	54	8
1	33.4	25.4	38.1	22.2	56	38.1	50.8	50.8	101.6	64	10
1 1/4	42.1	31.75	47.6	25.0	70	38.1	63.5	50.8	101.6	74	12
1 1/2	48.3	38.1	57.15	28.6	83	38.1	73.0	50.8	101.6	84	12
2	60.3	50.8	76.2	35.0	106	44*	92.0	63.5	152.4	102	16
2 1/2	73.0	63.5	95.25	44.0	132	51	106	63.5	152.4	122	16
3	88.9	76.2	114.3	50.8	159	64*	127.0	63.5	152.4	138	18
3 1/2	101.6	88.9	133.35	57.2	184	76*	139.7	76.2	152.4	148	18
4	114.3	101.3	152.4	63.5	210	76*	157.2	76.2	152.4	158	20
5	141.3	127.0	190.5	79.4	262	89*	185.7	76.2	208.2	188	20
6	168.3	152.4	228.6	95.3	313	102*	218	88.9	203.2	212	25
8	219.1	203.2	304.8	127.0	414	127*	270.0	101.6	203.2	270	30
10	373.1	254.0	381.0	158.7	518	152*	324.0	127.0	254.0	325	30
12	323.9	304.8	457.2	190.5	619	178*	381.0	152.4	254.0	380	35
14	355.6	355.6	533.4	222.2	711	191*	412.8	152.4	305.0	415	40
16	406.4	406.4	609.6	254.0		203*	470.0	152.4	305.0	470	40

* All dimensions are in mm

NOM BORE	PIPE OD	RADIUS 'R'					E/E1	LENGTH 'L'			
		1 D	1.5 D	B 1.5 D	K	G		MSS SP 43	ANSI B 16.9	D	H
		18	457.2	457.2	685.8	285.7		914	229*	533.4	152.4
20	508.0	508.0	762.0	317.6	1016	254*	584.2	152.4	305.0	585	40
22	558.8	558.8	838.2	343.0	1118	254*	641.4	152.4	305.0	642	40
24	609.6	609.6	914.4	381.0	1219	305*	692.2	152.4	305.0	693	40
26	660.0	660.0	991.0	405.0	—	267.0	—	—	—	—	—
28	711.0	711.0	1067.0	438.0	—	267.0	—	—	—	—	—
30	762.0	762.0	1143.0	470.0	—	267.0	—	—	—	—	—
32	813.0	813.0	1219.0	502.0	—	267.0	—	—	—	—	—
34	864.0	864.0	1295.0	533.0	—	267.0	—	—	—	—	—
36	914.0	914.0	1372.0	565.0	—	267.0	—	—	—	—	—
38	965.0	965.0	1448.0	600.0	—	305.0	—	—	—	—	—
40	1016.0	1016.0	1524.0	632.0	—	305.0	—	—	—	—	—
42	1067.0	1067.0	1600.0	660.0	—	305.0	—	—	—	—	—
44	1118.0	1118.0	1676.0	695.0	—	343.0	—	—	—	—	—
46	1168.0	1168.0	1753.0	727.0	—	343.0	—	—	—	—	—
48	1219.0	1219.0	1829.0	759.0	—	343.0	—	—	—	—	—
—	—	—	—	—	—	—	—	—	—	—	—

EDGE PREPARATION AS PER ANSI B 16.9 - B 16.25

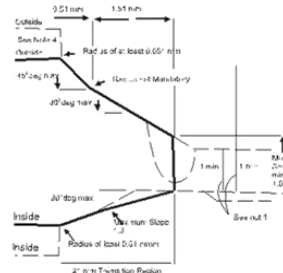
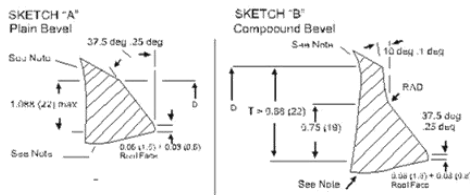

Normal Wall Thickness	End Preparation
Less than x*	Cut square or slightly Chamfer, at mrfs option
X* to 0.88 incl (22)	Chamfer, at mrfs option A above
More than 0.88 (22)	Compound bevel as in sketch B above
	X* = 0.19 (5) for Carbon Steel or Ferritic Alloy Steel and 0.12 (4) For Austenitic Alloy Steel

- The Value 1 min is whichever of the following is applicable
 - the minim ordered wall thickness of the pipe
 - 0.875 time the nominal wall thickness of pipe ordered to a pipe schedule wall thickness which has as under tolerance of 12.5%
 - The Maximum thickness at the end of the component is :
 - the greater of 1 min. + 0.15 in. (4 mm) or 1.15 in. (4 mm) or 1.15 t min. When ordered on a minimum wall basis
 - the greater of t min. + 0.15 in (4 mm) or 1.10 t nom. When ordered on a nominal wall basis
 - Weld bevel is shown for illustration only.
 - When transitions using maximum slope do no intersect outside surface, as shown by phantom outline, maximum Slopes shown or alternate radii shown in phantom outlines shall be used.
 - Dimension is parenthesis are in millimeters. Other are in inches.
- Note : 2. The shape of cap shall be ellipsoidal
 Note : 2. Of Specification ANSI b 16.9 for cap E1 & e2 to be consider
 Length E1 applies for thickness greater than that given in column " Limiting Wall Thickness" for NPS 24 (DIN 600) & Smaller.
 For NPS 25 (DN 650) and larger, length E1 Shall by agreement between manufacturer and purchaser

* E1 Height



Butt Welding Pipe Fitting Dimensional Standard Ansi B-16.9 /16.28 / Mss Sp-43

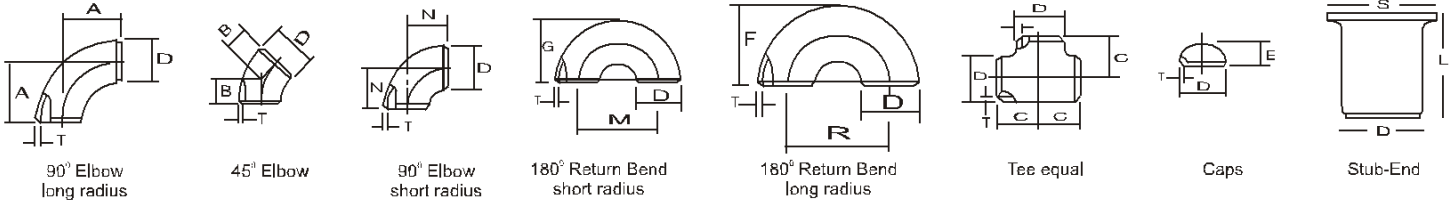

Nominal Pipe Size		Outside Diameter	Center to Face				Back to Face			Center to Center			Length 'L'	
Inch.	mm	D	A	B	C	N	E	F	G	R	M	S	MSS SP43	ANSI B 16.9
1/2	15	21.3	19	16	25	—	25	48	—	38	—	34.9	50.8	76.2
3/4	20	26.7	29	11	29	—	25	43	—	57	—	42.8	50.8	76.2
1	25	33.4	38	22	38	25	38	56	41	76	51	50.8	50.8	101.6
1 1/4	32	42.2	48	25	48	32	38	70	52	95	64	63.5	50.8	101.6
1 1/2	40	48.3	57	29	57	38	38	83	62	114	76	73	50.8	101.6
2	50	60.3	76	35	64	51	38	106	81	152	102	92	63.5	152.4
2 1/2	65	73.0	95	44	76	64	38	132	100	191	127	104.8	63.5	152.4
3	80	88.9	114	51	86	76	51	159	121	229	152	127	63.5	152.4
3 1/2	90	101.6	133	57	95	89	64	184	140	267	178	139.7	76.2	152.4
4	100	114.3	152	64	105	102	64	210	159	305	203	157.2	76.2	152.4
5	125	141.3	190	79	124	127	76	262	197	381	254	185.7	76.2	203.2
6	150	168.3	229	95	143	152	89	313	237	457	305	215.9	88.9	203.2
8	200	219.1	305	127	178	203	102	414	313	610	406	270	101.6	203.2
10	250	273.1	381	159	216	254	127	518	391	762	508	324	127.0	254.0
12	300	323.9	457	190	254	305	152	619	467	914	610	381	152.4	254.0
14	350	355.6	533	222	279	356	165	711	533	1067	711	412.8	152.4	305.0
16	400	406.4	610	254	305	406	178	813	610	1219	813	470	152.4	305.0
18	450	457.2	686	286	343	457	203	914	686	1372	914	533.4	152.4	305.0
20	500	508.0	762	318	381	508	229	1016	762	1524	1016	584.2	152.4	305.0
22	550	559.0	838	343	419	559	254	1118	838	1676	1118	614.4	152.4	305.0
24	600	610.0	914	381	432	610	267	1219	914	1829	1219	692.2	152.4	305.0
26	650	660.0	991	406	495	660	267	—	—	—	—	—	—	—
28	700	711.0	1067	438	521	711	267	—	—	—	—	—	—	—
30	750	762.0	1143	470	559	762	267	—	—	—	—	—	—	—
32	800	813.0	1219	502	597	813	267	—	—	—	—	—	—	—
34	850	864.0	1295	533	635	864	267	—	—	—	—	—	—	—
36	900	914.0	1372	565	673	914	267	—	—	—	—	—	—	—
38	950	965.0	1448	600	711	965	305	—	—	—	—	—	—	—
40	1000	1016.0	1524	632	749	1016	305	—	—	—	—	—	—	—
42	1050	1067.0	1600	660	762	1067	305	—	—	—	—	—	—	—
44	1100	1118.0	1676	695	813	1118	343	—	—	—	—	—	—	—
46	1150	1168.0	1753	727	851	1168	343	—	—	—	—	—	—	—
48	1200	1219.0	1829	759	889	1219	343	—	—	—	—	—	—	—

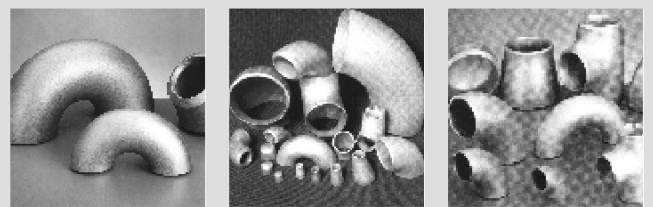

Dimensions Of Butt Welding Fittings To Ansi B16.9 (Upto 48")/ Mss Sp 43 (Upto 24")

EQUAL TEE & CROSS

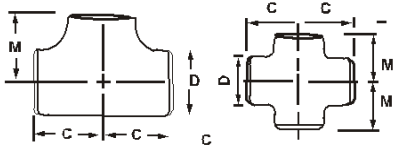

UNEQUAL TEE & CROSS

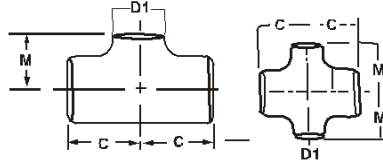

CONCENTRIC & ECCENTRIC REDUCERS

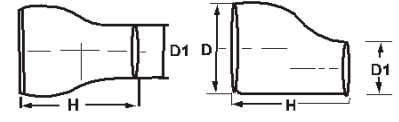

Nominal Pipe Size	Center to End Run	Center to End Branch	Length	Nominal Pipe Size	Center to End Run	Center to End Branch	Length	Nominal Pipe Size	Center to End Run	Center to End Branch	Length	Nominal Pipe Size	Center to End Run	Center to End Branch	Length	Nominal Pipe Size	Center to End Run	Center to End Branch	Length	Nominal Pipe Size	Center to End Run	Center to End Branch	Length
D X D1	C	M	H	D X D1	C	M	H	D X D1	C	M	H	D X D1	C	M	H	D X D1	C	M	H	D X D1	C	M	H
1x1	38	38	-	5x5	124	124	-	18X18	343	343	-	30X30	559	559	-	38X38	711	711	-	44X44	813	762	-
1x1/2	38	38	51	5x2	124	105	127	18X16	343	330	381	30X28	559	546	610	38X36	711	711	610	44X42	813	762	610
1x3/4	38	38	51	5X2 1/2	124	108	127	18X14	343	330	381	30X26	559	546	610	38X34	711	698	610	44X40	813	749	610
1 1/4x1 1/4	48	48	51	5X3	124	111	127	18X12	343	321	381	30X24	559	533	610	38X32	711	686	610	44X38	813	737	610
1 1/4x1/2	48	48	51	5X3 1/2	124	114	127	18X10	343	308	381	30X22	559	521	610	38X30	711	673	610	44X36	813	724	610
1 1/4x3/4	48	48	51	5X4	124	117	127	18X8	343	298	(381)	30X20	559	(508)	(610)	38X28	711	648	610	44X34	813	724	(610)
1 1/4x1	48	48	51	5x6	143	143	-	20x20	381	381	-	30X18	559	(495)	(610)	38X26	711	648	610	44X32	813	711	(610)
1 1/2x1 1/2	57	57	-	5x2 1/2	143	121	140	20x18	381	368	508	30X16	559	(483)	(610)	38X24	711	635	(610)	44X30	813	711	(610)
1 1/2x1/2	57	57	64	6x3	143	124	140	20x16	381	356	508	30X14	559	(483)	(610)	38X22	711	622	(610)	44X28	813	698	(610)
1 1/2x3/4	57	57	64	6x3 1/2	143	127	140	20x14	381	356	508	30X12	559	(473)	(610)	38X20	711	610	(610)	44X26	813	698	(610)
1 1/2x1	57	57	64	6x4	143	130	140	20x12	381	346	508	30X10	559	460	(610)	38X18	711	597	(610)	44X24	813	698	(610)
1 1/2x1 1/4	57	57	64	6x5	143	137	140	20X10	381	333	(508)	32x32	597	597	-	40x40	749	749	-	44X22	813	686	(610)
2x2	64	64	-	8x8	178	178	-	20x8	381	324	(508)	32x30	597	584	610	40x38	749	749	610	44X20	813	686	(610)
2x3/4	64	44	76	8x6	178	168	152	22x22	419	419	-	32x28	597	572	610	40x36	749	737	610	46x46	851	800	-
2x1	64	51	76	8x5	178	162	152	22x20	419	406	508	32x26	597	572	610	40x34	749	724	610	46x44	851	800	711
2x1 1/4	64	57	76	8x4	178	156	152	22x18	419	384	508	32x24	597	558	610	40x32	749	711	610	46x42	851	787	711
2x1 1/2	64	60	76	8x3 1/2	178	152	152	22x16	419	381	508	32x22	597	546	(610)	40x30	749	698	610	46x40	851	775	711
2 1/2x2 1/2	76	76	-	10x10	216	216	-	22x14	419	381	508	32x20	597	533	(610)	40x28	749	673	(610)	46x38	851	762	711
2 1/2x1	76	57	89	10x8	216	203	178	22x12	419	371	(508)	32x18	597	521	(610)	40x26	794	673	(610)	46x36	851	762	(711)
2 1/2x1 1/4	76	64	89	10x6	216	194	178	22x10	419	359	(508)	32x16	597	508	(610)	40x24	749	660	(610)	46x34	851	749	(711)
2 1/2x1 1/2	76	67	89	10x5	216	191	178	24x24	432	432	-	32x14	597	508	(610)	40x22	749	648	(610)	46x32	851	749	(711)
2 1/2x2	76	70	89	10x4	216	184	178	24x22	432	432	508	34x34	635	635	-	40x20	749	635	(610)	46x30	851	737	(711)
3x3	89	89	-	12x12	254	254	-	24x20	432	432	508	34x32	635	622	610	40x18	749	622	(610)	46x28	851	737	(711)
3x1 1/4	86	70	89	12x10	254	241	203	24x18	432	419	508	34x30	635	610	610	42x42	762	711	-	46x26	851	737	(711)
3x1 1/2	86	73	89	12x8	254	229	203	24x16	432	406	508	34x28	635	597	610	42x40	762	711	610	46x24	851	724	(711)
3x2	86	76	89	12x6	254	219	203	24x14	432	406	(508)	34x26	635	597	610	42x38	762	711	610	46x22	851	724	(711)
3x2 1/2	86	83	89	12x5	254	216	203	24x12	432	397	(508)	34x24	635	584	(610)	42x36	762	711	610	48x48	889	838	-
3 1/2x3 1/2	95	95	-	14x14	279	279	-	24x10	432	384	(508)	34x22	635	572	(610)	42x34	762	711	610	48x46	889	838	711
3 1/2x1 1/2	95	79	102	14x12	279	270	330	26x26	495	495	-	34x20	635	559	(610)	42x32	762	711	610	48x44	889	838	711
3 1/2x2	95	83	102	14x10	279	257	330	26x24	495	483	610	34x18	635	546	(610)	42x30	762	711	610	48x42	889	813	711
3 1/2x2 1/2	95	89	102	14x8	279	248	330	26x22	495	470	610	34x16	635	533	(610)	42x28	762	698	(610)	48x40	889	813	711
3 1/2x3	95	92	102	14x6	279	238	330	26x20	495	457	610	36x36	673	673	-	42x26	762	698	(610)	48x38	889	813	(711)
4x4	105	105	-	16x16	305	305	-	26x18	495	444	610	36x34	673	660	610	42x24	762	660	(610)	48x36	889	787	(711)
4x1 1/2	105	86	102	16x14	305	305	356	26x16	495	432	(610)	36x32	673	648	610	42x22	762	660	(610)	48x34	889	787	(711)
4x2	105	89	102	16x12	305	295	356	26x14	495	432	(610)	36x30	673	635	610	42x20	762	660	(610)	48x32	889	787	(711)
4x2 1/2	105	95	102	16x10	305	283	356	26x12	495	422	(610)	36x28	673	622	610	42x18	762	648	(610)	48x30	889	762	(711)
4x3	105	98	102	16x8	305	273	356	28x28	521	521	-	36x26	673	622	610	42x16	762	635	(610)	48x28	889	762	(711)
4x3 1/2	105	102	102	16x6	305	264	(356)	28x26	521	521	610	36x24	673	610	(610)	48x26	889	762	(711)	48x26	889	762	(711)
								28x24	521	508	610	36x22	673	597	(610)	48x24	889	737	(711)	48x24	889	737	(711)
								28x22	521	495	610	36x20	673	584	(610)	48x22	889	737	(711)				
								28x20	521	483	610	36x18	673	572	(610)								
								28x18	521	470	(610)	36x16	673	559	(610)								
								28x16	521	457	(610)												
								28x14	521	457	(610)												
								28x12	521	448	(610)												

1. Figures in brackets are as per the Manufacturer's standard

2. Outlet dimension M For run size NPS 14 (DN 350) and large is recommended but not required

All dimensions are in mm

Dimensional Tolerance Ansi B16.9/B16.28/Mss Sp-43

ALL FITTINGS				90°/60°/45° 30° ELBOWS & TEES		REDUCERS		180° RETURNS				CAPS		ANGULARITY TOLERANCE					
Nominal Pipe size INCH/MM	Outside Diameter at Bevel	Inside Dia Meter	Wall Thickness at End	Center to End	Overall Length Dimension	Center to End	Back to Face Dimension	Alignment of End Dimensions	Overall Length	Nominal Pipe Size	Off Angel Inch/mm	Off Plane							
D		T		A,B,C,M	H	O	K	U	E	Q			P						
(1) B16.9	MSS Sp43	(2) B16.9	B16.9	MSS SP43	B16.9	MSS SP43	B16.9	MSS SP43	B16.9	MSS SP43	B16.9	MSS SP43	B16.9	MSS SP75	B16.9				
1/2" - 2 1/2" 15 - 65	±1.6 -0.8	±0.8	±0.8	Not Less Than 87.5% Nominal Thk	Not Less Than 87.5% Nominal Thk	FROM 1/2" TO 18 15 TO 600	FROM 3/4"	FROM 1/2" - 24" 15 - 600	FROM 1/2" - 8" 15 - 200				±3	±3.17	1/2" - 4" 15 - 100	±1	16" - 24" 400 - 600 1.6	±2	
3" - 3 1/2" 80 - 90	±1.6					±0.80	±2	±1.60	±2	±1.60	±6	±6.35	±6.0	±6.4	±1	±0.8		5" - 8" 125 - 200	±2
4" 100	+2.4 -1.6	+1.60 -0.80	±1.6	Not Less Than 87.5% Nominal Thk	Not Less Than 87.5% Nominal Thk	±2.40	10" - 24" +2.38 250 - 600	±10	±10					±6	±6.35	10" - 12" 250 - 300	±3	±5	
5" - 6" 125 - 150																±1.6	±0.80		±2
8" 200																			
10" - 18" 250 - 450	+4 -3.2	+2.38 -0.80	±3.2																
20" - 24" 500 - 600	+6.4 -4.8	3.17 0.79																	
26" - 30" 650 - 750	+6.4 -4.8	±4.8	±4.8																
32" - 48" 800 - 1200	+6.4 -4.8																		

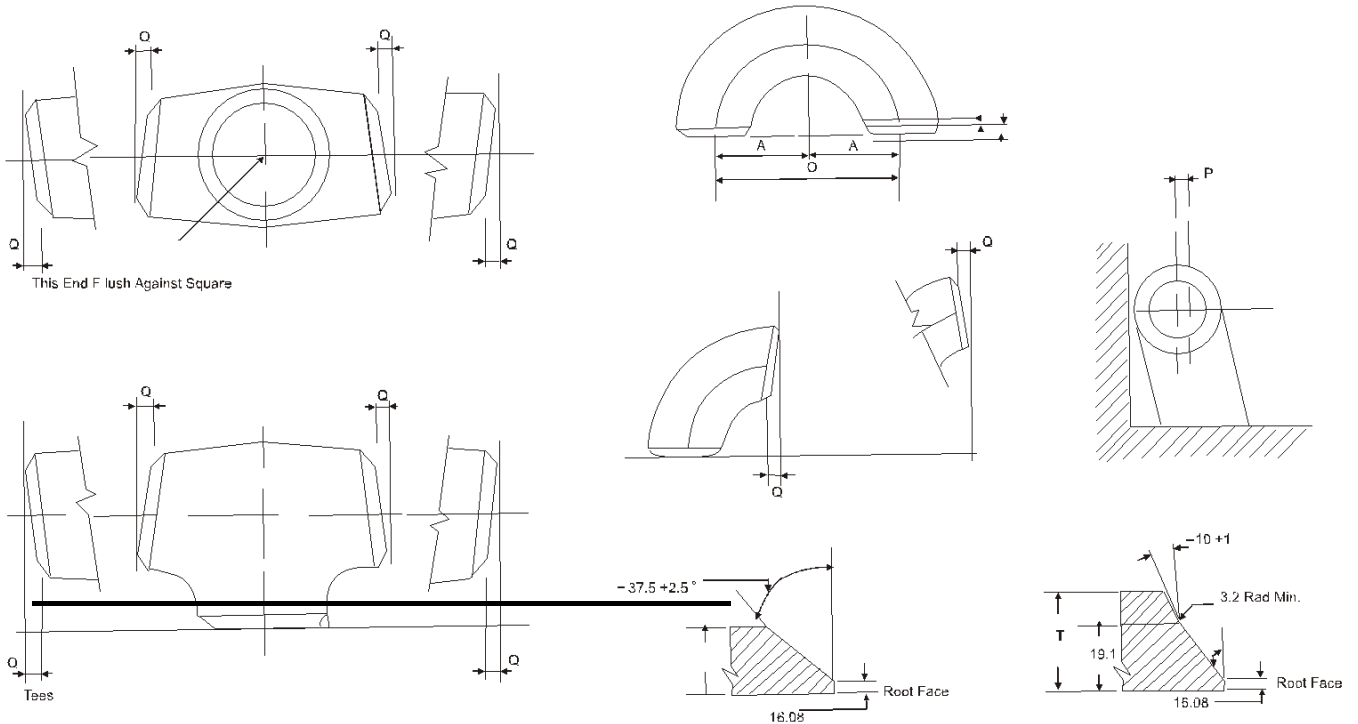

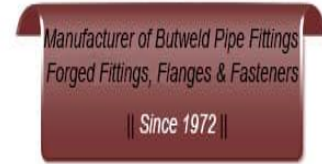

Weights Of Fittings 90 Elbows (L.R) Butt-Weld (Ansi B16.9)

NB INCHES METRIC		(Weights in.KGS.)																
		SCH 5 S	SCH 10 S	SCH 10	SCH 20	SCH 30	SCH 40 S	SCH STD	SCH 40	SCH 60	SCH 80 S	SCH XS	SCH 80	SCH 100	SCH 120	SCH 140	SCH 160	SCH XXS
1/2	15	0.1	0.1	-	-	-	0.1	0.1	-	-	0.1	0.1	-	-	-	-	0.1	0.1
3/4	20	0.1	0.1	-	-	-	0.1	0.1	-	-	0.1	0.1	-	-	-	-	0.2	0.2
1	25	0.1	0.2	-	-	-	0.2	0.2	-	-	0.2	0.2	-	-	-	-	0.3	0.4
1-1/4	32	0.1	0.2	-	-	-	0.3	0.3	-	-	0.4	0.4	-	-	-	-	0.5	0.6
1-1/2	40	0.2	0.3	-	-	-	0.4	0.4	-	-	0.6	0.6	-	-	-	-	0.7	1.0
2	50	0.3	0.5	-	-	-	0.7	0.7	-	-	1.0	1.0	-	-	-	-	1.4	1.7
2-1/2	65	0.6	0.9	-	-	-	1.4	1.4	-	-	1.5	1.5	-	-	-	-	2.5	3.2
3	80	1.0	1.3	-	-	-	2.5	2.5	-	-	2.9	2.9	-	-	-	-	3.8	5.5
3-1/2	90	1.2	1.7	-	-	-	3.0	3.0	-	-	4.0	4.0	-	-	-	-	-	8
4	100	1.6	2.1	-	-	-	4.0	4.0	-	-	6.0	6.0	-	-	7.5	-	9	12
5	125	2.7	3.7	-	-	-	6.8	6.8	-	-	9.3	9.3	-	-	2.7	-	15	18
6	150	4.4	5.5	-	-	-	11	11	-	-	17	17	-	-	23	-	26	30
8	200	9	10	-	17	19	22	22	-	27	35	35	-	38	41	52	55	54
10	250	17	18	-	26	33	42	42	-	54	54	61	-	75	85	97	109	-
12	300	24	27	-	37	49	60	60	61	82	80	80	107	123	140	157	180	-
14	350	28	40	50	59	70	70	70	83	109	94	94	135	188	190	224	248	-
16	400	38	52	64	78	95	95	95	125	162	125	125	202	260	274	323	367	-
18	450	48	65	82	100	139	120	120	176	232	158	158	291	390	405	422	545	-
20	500	58	85	100	146	194	146	146	228	311	194	194	391	476	508	607	770	-
22	550	-	-	120	-	-	-	178	-	-	236	-	-	-	-	-	-	-
24	600	88	146	146	220	318	220	220	383	533	282	282	658	820	954	1100	1270	-

90 ELBOWS (S R) BUTT-WELD (ANSI B16.28)

NB INCHES METRIC		(Weights in.KGS.)																
		SCH 5 S	SCH 10 S	SCH 10	SCH 20	SCH 30	SCH STD	SCH 40	SCH 60	SCH XS	SCH 80	SCH 100	SCH 120	SCH 140	SCH 160	SCH XXS		
1/2	15	0.1	0.1	-	-	-	0.1	-	-	0.1	-	-	-	-	-	-	-	-
3/4	20	0.1	0.1	-	-	-	0.1	-	-	0.1	-	-	-	-	-	-	-	-
1	25	0.1	0.1	-	-	-	0.1	-	-	0.1	-	-	-	-	-	-	-	-
1-1/4	32	0.1	0.2	-	-	-	0.2	-	-	0.3	-	-	-	-	-	-	-	-
1-1/2	40	0.1	0.2	-	-	-	0.3	-	-	0.4	-	-	-	-	-	-	-	-
2	50	0.2	0.4	-	-	-	0.5	-	-	0.7	-	-	-	-	-	-	-	-
2-1/2	65	0.4	0.6	-	-	-	1.1	-	-	1.1	-	-	-	-	-	-	-	-
3	80	0.8	1.0	-	-	-	2.0	-	-	2.0	-	-	-	-	-	-	-	-
3-1/2	90	0.9	1.3	-	-	-	2.3	-	-	3.0	-	-	-	-	-	-	-	-
4	100	1.2	1.6	-	-	-	3.0	-	-	4.2	-	-	4.5	-	-	-	-	-
5	125	2.1	2.7	-	-	-	5.1	-	-	6.5	-	-	9	-	-	-	-	-
6	150	3.3	4.1	-	-	-	8.3	-	-	11.8	-	-	13.5	-	-	-	-	-
8	200	6.6	7.7	-	11.1	11.4	17	-	18.2	24.4	-	26.4	29	32	-	-	-	-
10	250	12.5	13.6	-	17.4	21.4	31	-	37.7	37.7	41	50	53	62	-	-	-	-
12	300	18	20.5	-	25.0	33.2	45	48	54.5	56.0	68	81	92	99	-	-	-	-
14	350	21	30	38	39.5	52.5	52.5	55	74.0	66.0	94	124	120	138	-	-	-	-
16	400	29	38.7	48	52.2	71.3	71.3	104	106.7	104.3	138	171	166	198	-	-	-	-
18	450	36	49.1	62	65.4	92.2	90	118	154.4	110.6	193	257	283	387	-	-	-	-
20	500	44	63.7	75	110	136	110	155	208.0	135.8	261	332	376	430	-	-	-	-
22	550	-	-	90	-	-	-	-	-	-	-	-	-	-	-	-	-	-
24	600	66	110	110	165	214.3	165	257	355.5	197.5	444	530	621	680	-	-	-	-

WEIGHT ARE APPROXIMATE

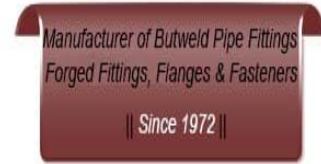

Weights Fittings 45 Deg. Elbows Buttwelded (Ansi B16.9)

NB INCHES	SIZE MM	SCH 5 S	SCH 10 S	SCH 10	SCH 20	SCH 30	(WEIGHTS IN KGS.)				SCH 80 S	SCH X S	SCH 80	SCH 100	SCH 120	SCH 140	SCH 160	SCH XXS
							SCH 40 S	SCH STD	SCH 40	SCH 60								
1/2	15	0.1	.1	-	-	-	0.1	0.1	-	-	0.1	0.1	-	-	-	-	0.1	0.1
3/4	20	0.1	.1	-	-	-	0.1	0.1	-	-	0.1	0.1	-	-	-	-	0.1	0.1
1	25	0.1	.1	-	-	-	0.1	0.1	-	-	0.1	0.1	-	-	-	-	0.1	0.2
1 1/4	32	0.1	.1	-	-	-	0.1	0.1	-	-	0.2	0.2	-	-	-	-	0.2	0.3
1 1/2	40	0.1	.2	-	-	-	0.2	0.2	-	-	0.3	0.3	-	-	-	-	0.3	0.5
2	50	0.2	.3	-	-	-	0.4	0.4	-	-	0.5	0.5	-	-	-	-	0.7	0.9
2 1/2	65	0.3	.4	-	-	-	0.7	0.7	-	-	0.8	0.8	-	-	-	-	1.3	1.6
3	80	0.5	.6	-	-	-	1.3	1.3	-	-	1.5	1.5	-	-	-	-	2	2.5
3 1/2	90	0.6	.8	-	-	-	1.5	1.5	-	-	2.0	2.0	-	-	-	-	-	4
4	100	0.8	1.1	-	-	-	2.0	2.0	-	-	3.0	3.0	-	-	3.8	-	4.5	5
5	125	1.4	1.6	-	-	-	3.4	3.4	-	-	4.7	4.7	-	-	6.4	-	7.5	9
6	150	2.2	2.7	-	-	-	5.5	5.5	-	-	6.4	6.4	-	-	11.5	-	13	15
8	200	4.4	5.1	-	10	10	11	11	-	13.5	17.4	17.4	-	19	20.3	26	27.5	27
10	250	8.3	9.1	-	18.5	16	21	21	-	27	27	27	31	37.5	42.5	49	54.4	-
12	300	12	13.6	-	24.8	24.5	30	30	31	41	40	40	54	61.5	70	79	90	-
14	350	14	20	25	37	35	35	41	41	54.5	47	47	68	94	95	112	124	-
16	400	19	26	32	46.5	47.5	47.5	47.5	63	81	62.5	62.5	101	130	137	162	183	-
18	450	24	33	41	56	69.5	60	60	87	116	79	79	145	195	203	211	273	-
20	500	29	42.5	50	73	97	73	73	114	156	97	97	195	238	254	304	385	-
22	550	-	-	60	-	-	90	-	-	-	-	-	118	-	-	-	-	-
24	600	44	73	73	110	159	110	110	191	267	141	141	334	410	477	545	635	-

END CAPS BUTT-WELD (ANSI B 16.9)

NB INCHES	SIZE MM	SCH 5 S	SCH 10 S	SCH 10	SCH 20	SCH 30	(WEIGHTS IN KGS.)				SCH 80 S	SCH X S	SCH 80	SCH 100	SCH 120	SCH 140	SCH 160	SCH XXS
							SCH 40 S	SCH STD	SCH 40	SCH 60								
1/2	15	0.1	0.1	-	-	-	0.1	0.1	-	-	0.1	0.1	-	-	-	-	-	-
3/4	20	0.1	0.1	-	-	-	0.1	0.1	-	-	0.1	0.1	-	-	-	-	-	-
1	25	0.1	0.1	-	-	-	0.1	0.1	-	-	0.2	0.1	-	-	-	-	0.2	0.2
1 1/4	32	0.1	0.1	-	-	-	0.2	0.2	-	-	0.2	0.2	-	-	-	-	0.3	0.3
1 1/2	40	0.1	0.1	-	-	-	0.2	0.2	-	-	0.3	0.3	-	-	-	-	0.3	0.4
2	50	0.1	0.1	-	-	-	0.3	0.3	-	-	0.3	0.3	-	-	-	-	0.6	0.5
2 1/2	65	0.2	0.2	-	-	-	0.4	0.4	-	-	0.5	0.5	-	-	-	-	0.9	1
3	80	0.3	0.4	-	-	-	0.7	0.7	-	-	0.9	0.9	-	-	-	-	1.5	1.8
3 1/2	90	0.4	0.5	-	-	-	1	1	-	-	1.3	1.3	-	-	-	-	-	2.8
4	100	0.4	0.6	-	-	-	1.1	1.1	-	-	1.6	1.6	-	-	2.5	-	2.8	3.5
5	125	0.8	1	-	-	-	2	2	-	-	2.7	2.7	-	-	4	-	5	5.5
6	150	1.2	1.5	-	-	-	3	3	-	-	4.4	4.4	-	-	6	-	7.5	8.1
8	200	2.2	2.8	-	4.5	5	5.5	5.5	5.5	7	8.4	8.4	15.09	11	12.27	14	19	14.91
10	250	3.6	4.6	-	6	8	9	9	-	13	13.6	13.6	18.25	21	30	30	33	29.30
12	300	6	7.5	-	10	13	15	15	19	25.5	22.5	22.5	29.5	32.5	41	46	53	-
14	350	6.4	8.2	14	13.5	16	16	16	24	38	27	27	36.3	50	59	67	76	-
16	400	8.4	10.7	18	18	21	21	21	31	52	31.5	31.5	52.3	64	75	90	99	-
18	450	10.4	13	22	22	30	26	26	42	66	36	36	72.5	75	88	93	104	-
20	500	13.6	17	29	34	42	34	34	56.8	78	42	42	98.5	122	143	153	170	-
22	550	15	20	35.5	39	42	39	39	-	94.5	51	51	126	154	182	210	240	-
24	600	20.8	26	44	52	74.5	52	52	96.5	120	60	60	150	186	220	250	285	-

WEIGHTS ARE APPROXIMATE



Weights Fittings Equal / Unequal Tees Buttweld (Ansi B16.9)

NB INCHES METRIC		SCH 5 S	SCH 10 S	SCH 10	SCH 20	SCH 30	(Weights in.KGS.)					SCH XS	SCH 80	SCH 100	SCH 120	SCH 140	SCH 160	SCH XXS
							SCH 40 S	SCH STD	SCH 40	SCH 60	SCH 80 S							
1/2	15	0.1	0.1	-	-	-	0.2	0.2	-	-	0.3	0.3	-	-	-	-	0.3	0.3
3/4	20	0.1	0.1	-	-	-	0.2	0.2	-	-	0.4	0.4	-	-	-	-	0.5	0.5
1	25	0.2	0.3	-	-	-	0.4	0.4	-	-	0.5	0.5	-	-	-	-	0.9	0.7
1 1/4	32	0.4	0.5	-	-	-	0.9	0.9	-	-	1.1	1.1	-	-	-	-	1.3	1.2
1 1/2	40	0.6	0.7	-	-	-	1.4	1.4	-	-	1.5	1.5	-	-	-	-	1.9	2.0
2	50	0.7	1.7	-	-	-	1.7	1.7	-	-	2.2	2.2	-	-	-	-	3.2	3.0
2 1/2	65	1.1	2.2	-	-	-	2.7	2.7	-	-	3.0	3.0	-	-	-	-	4.0	4.5
3	80	1.5	3.0	-	-	-	3.8	3.8	-	-	3.8	3.8	-	-	-	-	6.6	7.1
3 1/2	90	2.0	4.1	-	-	-	5.0	5.0	-	-	5.3	5.3	-	-	-	-	-	11
4	100	2.6	4.4	-	-	-	6.5	6.5	-	-	7.7	7.7	-	-	9	-	17	15
5	125	4.0	7.4	-	-	-	10	10	-	-	13.5	13.5	-	-	18	-	25	24
6	150	6.4	12.4	-	-	-	16	16	-	-	19.3	19.3	-	-	24	-	40	38
8	200	10.7	20.0	-	23	25	27	27	-	32	33	33	-	44	50	54	71	68
10	250	18.0	28.2	-	35	40	45	45	-	60	60	60	68	74	93	99	120	-
12	300	26.0	47.5	-	59	57	65	65	71	95	78	78	115	136	150	176	184	-
14	350	40.7	69.9	87.2	95	102	102	102	105	135	115	115	165	206	240	275	300	-
16	400	44	72.7	90.8	100	110	110	110	167	206	167	167	249	335	330	385	420	-
18	450	54	101.7	127.1	127	164	135	135	237	277	190	190	322	380	450	500	500	-
20	500	67	169.8	199.8	168	245	168	168	320	379	245	245	459	540	590	720	790	-
22	550	-	-	220	-	-	-	220	-	-	-	280	-	-	-	-	-	-
24	600	100	306.5	310.0	240	373	240	240	571	654	350	350	748	910	1100	1180	1310	-

CON. / ECC. REDUCER BUTT-WELD (ANSIB16.9)

NB INCHES METRIC		SCH 5 S	SCH 10 S	SCH 10	SCH 20	SCH 30	(Weights in.KGS.)					SCH XS	SCH 80	SCH 100	SCH 120	SCH 140	SCH 160	SCH XXS
							SCH 40 S	SCH STD	SCH 40	SCH 60	SCH 80 S							
3/4	20	0.1	0.1	-	-	-	0.1	0.1	-	-	0.1	0.1	-	-	-	-	0.2	0.2
1	25	0.1	0.1	-	-	-	0.1	0.1	-	-	0.2	0.2	-	-	-	-	0.2	0.2
1 1/4	32	0.1	0.1	-	-	-	0.2	0.2	-	-	0.2	0.2	-	-	-	-	0.3	0.3
1 1/2	40	0.1	0.2	-	-	-	0.3	0.3	-	-	0.4	0.4	-	-	-	-	0.5	0.5
2	50	0.1	0.2	-	-	-	0.4	0.4	-	-	0.6	0.6	-	-	-	-	1.0	0.9
2 1/2	65	0.3	0.4	-	-	-	0.8	0.8	-	-	1.0	1.0	-	-	-	-	1.4	1.4
3	80	0.4	0.5	-	-	-	1.0	1.0	-	-	1.4	1.4	-	-	-	-	1.9	1.8
3 1/2	90	0.6	0.7	-	-	-	1.3	1.3	-	-	1.9	1.9	-	-	-	-	3.9	3.2
4	100	0.7	0.8	-	-	-	1.6	1.6	-	-	2.3	2.3	-	-	3.7	-	3.7	6.4
5	125	1.1	1.4	-	-	-	2.8	2.8	-	-	3.9	3.9	-	-	6.4	-	6.4	9.0
6	150	1.6	2.0	-	-	-	4.0	4.0	-	-	5.9	5.9	-	-	8	-	10	14.5
8	200	2.8	3.3	-	5.0	6	6.5	6.5	-	8	10	10	-	12	14	16	16.5	-
10	250	4.3	5.5	-	7.3	9	10.7	10.7	-	14.5	15	15	17.7	21	25	28	29.5	-
12	300	6.0	7.7	-	9.7	13	15.0	15.0	16.4	22.3	20	20	28.2	33	38	44	49	-
14	350	10.8	13.8	23	22.3	27	26.9	26.8	31.3	41.8	36	36	52.3	64	73	78	86	-
16	400	13.3	16.4	28	27.5	33	33.2	33.1	44.0	56.6	44	44	73.5	83	97	112	121	-
18	450	16.0	20.3	34	33.5	47	40.0	40.0	59.5	77.4	53	53	97.6	116	136	145	159	-
20	500	23.8	29.8	50	59.5	79	59.4	59.4	93.0	125	79	79	159	163	178	305	340	-
22	550	-	-	57	-	-	-	-	-	-	-	87	-	-	-	-	-	-
24	600	28.7	36.3	63	71.7	107	71.7	71.7	129.4	181	95	95	228	241	295	540	610	-

WEIGHT ARE APPROXIMATE